



VILLAGE OF RIDGEWOOD

DEPARTMENT OF PUBLIC WORKS
131 N MAPLE AVENUE - RIDGEWOOD, NJ 07450

Christopher J. Rutishauser, P.E., C.P.W.M.
Director of Public Works/Village Engineer

Phone (201) 670-5500 ext 2238
Fax (201) 670-7305

CURB - SIDEWALK - APRON PERMIT

Notes:

- Driveway expansions require Zoning Review from the Building Department.
- All work must conform to ADA/PROWAG requirements
- Concrete mix shall be NJDOT Class B, air entrained concrete.
- Broom finish required on all surfaces. Sidewalk slab perimeter to be edged.
- Expansion joints spacing 10 feet max.
- Expansion joints shall be bituminous fiber or approved equal.
- Concrete shall be completely replaced to the nearest joint.
- Any valve covers, cleanouts, manholes, grates, doors, etc. must be set flush with sidewalk.
- Forms must be inspected prior to the pour. Forms shall be rigid and braced.
- Concrete shall be protected from weather when curing.
- Finish inspection required for final approval.
- See separate specs for Business District sidewalks and County road curb requirements.
- Contact Ridgewood Parks Dept. 3 days In advance to schedule root grinding. (201) 670-5565
- Contact Ridgewood Police Dept. if traffic closures are required. (201) 652-3900
- Contact NJ One Call for utility markout request. 1-800-272-1000
- See Village Code Chapter 249 for additional info. Code located online at www.ridgewoodnj.net

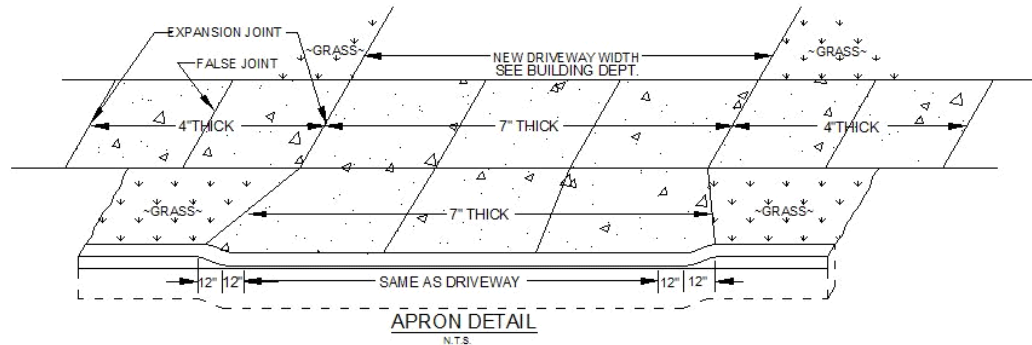
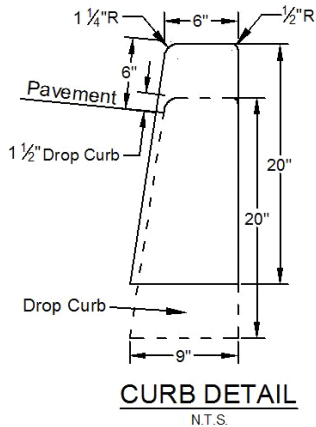

**VILLAGE OF RIDGEWOOD
CURB-SIDEWALK-APRON PERMIT
CALL ENGINEERING 1 DAY PRIOR TO INSPECTIONS
201-670-5500 Ext. 2238**

Permit No:

Date Issued:

WORK TO BE DONE

Work Site:

Curb / DropCurb

Owner:

Sidewalk

Email:

Phone No:

Apron

Contractor:

CBD Work

Email:

Phone No:

PERMIT HOLDER

Issued By:

Signature: _____

Permit Fee:

Inspection Notes: _____

Pymt Type:

(PERMIT EXPIRES IN 30 DAYS)